

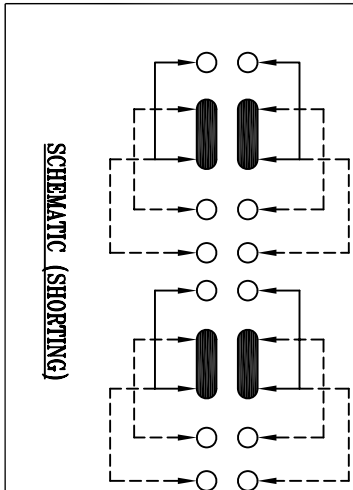

CAD FILE:

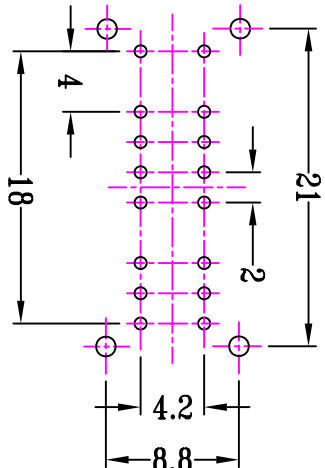
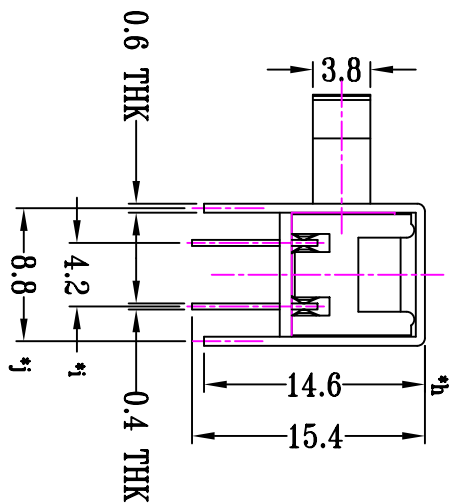
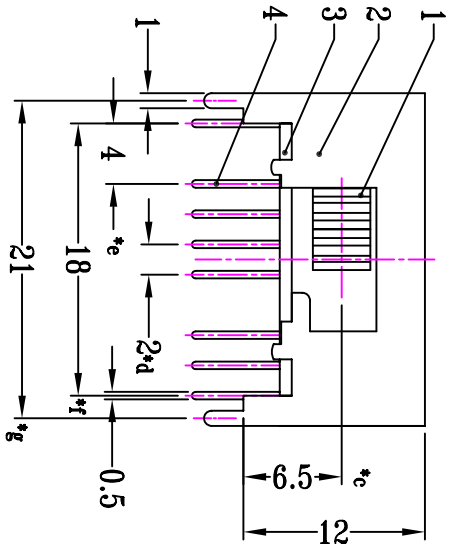
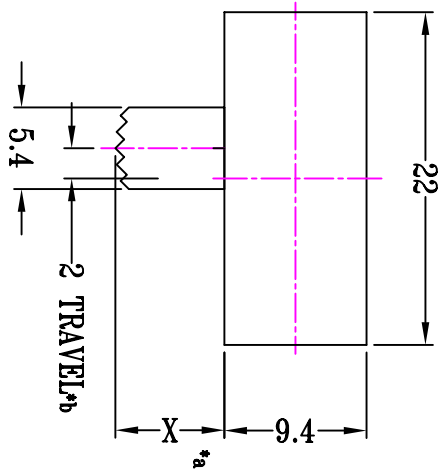

注: \*表示关键尺寸 (0.05)

8	STEEL BALL	STEEL	1	NATURAL	TOLERANCE UNLESS SPECIFIED		SHENZHEN XIEJIA ELECTRONICS CO.,LTD.	
7	SPRING	STEEL WIRE	1	TEMPER	WITHIN: 1.5±0.1mm		ISSUE	DATE
6	CONTACT CLIP	PBS STRIP	4	Ag PLATED	OVER: 1.5±0.2mm		DESCRIPTIONS OF REVISION	APPD.
4	TERMINAL	BRASS STRIP	16	Ag PLATED OVER Ni PLATED	TITLE : HORIZONTAL SLIDE SWITCH		UNIT : mm	DRWG NO.: XJ-DR-SK43D03-00
3	BASE	PHENOLIC RESIN	1	NATURAL	MODEL: SK-43D03		SCALE: 2:1	DWN. ZHOUYU 2004-11-5
2	FRAME	STEEL STRIP	1	Ni PLATED	ALL MATERIALS MUST BE COMPLIANT TO ROHS		CHK'D FANGYING 2004-11-5	APPD. KANGXIAN 2004-11-5
1	KNOB	POM	1	BLACK				
NO.	PARTS	MATERIALS	QTY	FINISH				